

# On MAC Layer Throughput Enhancements in LTE-A by Downlink Macro Diversity

S. Brueck, J. Giese, L. Zhao, A. Dekorsy  
Qualcomm CDMA Technologies  
Nordostpark 89, 90411 Nuremberg, Germany  
Email: {sbrueck, jgiese, luz, adekorsy}@qualcomm.com

**Abstract**—Coordinated transmission between base stations is one of the techniques under investigation to further improve the system performance of E-UTRA. In general, such a coordination, sometimes also called network MIMO, requires a large amount of signaling between cells. A relatively simple scheme for cell coordination is macro diversity. In this paper we consider macro diversity for the downlink direction of LTE-Advanced as a means to improve cell edge user throughput. We investigate the frequency-selectivity gains offered by over the air combining for different radio channels at link level. The impact on cell throughput as well as on user throughput for mobiles operated in macro diversity mode and for legacy mobile stations is investigated by means of system level simulations. Additionally, open issues related to network coordination are identified for future work.

## I. INTRODUCTION

In order to maintain future competitiveness of the 3GPP cellular system Long Term Evolution (LTE), also known as Evolved Universal Terrestrial Radio Access (E-UTRA), is currently being standardized [1]. Orthogonal frequency division multiple access (OFDMA) has been chosen for the downlink direction. Since time and frequency resources are typically reused in adjacent cells, inter cell interference becomes the limiting factor. In order to overcome this problem, interference mitigation techniques such as interference cancelation, interference coordination and interference randomization are currently investigated within 3GPP [1]. However, the performance improvements offered by these techniques are limited since inter cell interference cannot be completely removed. Another promising candidate to provide high spectral efficiency in downlink direction is coordinated transmission between base stations [2], also called network coordination or network MIMO. Network coordination is one of the techniques under investigation to achieve the spectral efficiency requirements for LTE-Advanced [3].

In general, network coordination requires significant amount of signaling between cells. As already identified in [1] macro diversity is a promising candidate for simple network coordination. It requires a relatively small signaling overhead compared to other network coordination schemes since it does not rely on complex signal processing algorithms at the transmitter or the receiver. The basic idea of macro diversity is that all involved cells are used for transmission of the same information to a mobile station (UE) thus reducing inter cell interference, improving the frequency-selectivity of the

channel as well as increasing the overall received power. An approach to further improve performance is preprocessing in the base station (eNB), e.g. space-frequency codes. This paper is focused on the first kind of gains of macro diversity without applying any form of precoding in the eNB.

The main purpose of the paper is to provide an initial performance assessment of potential macro diversity gains and identify open issues for future work. The paper is organized as follows: Section II provides a brief summary of LTE Rel. 8 numerology. In Section III the system model used in the paper is described and synchronization requirements for the physical layer as well as the MAC layer are presented. Simulation results at link and system level for a simplified scenario are shown and its impacts are discussed in Section IV. Conclusions are summarized in Section V.

## II. OVERVIEW OF 3GPP LTE RELEASE 8

The transmission on the LTE Physical Downlink Shared Channel (PDSCH) is based on Orthogonal Frequency Division Multiplex (OFDM). Transmission is organized in a frequency-time grid. The basic downlink physical resource element corresponds to one OFDM subcarrier during one OFDM symbol interval. The LTE Rel. 8 setup considered in this paper uses an OFDM subcarrier spacing of  $\Delta f = 15\text{kHz}$ . Subcarriers are grouped into resource blocks, where each resource block consists of 12 consecutive subcarriers resulting in a nominal resource block bandwidth of 180kHz. The time domain is organized in subframes, slots, and OFDM symbols. Each subframe (TTI) of length 1ms consists of two slots of length 0.5ms. Each slot then consists of 7 OFDM symbols each including a cyclic prefix of length  $5.2\mu\text{s}$  for the first symbol per slot and  $4.7\mu\text{s}$  for the remaining 6 OFDM symbols of the slot. Note that the parameters assumed above configure the LTE Rel. 8 setup for normal cyclic prefix. A physical resource block (PRB) consists of 7 OFDM symbols. Thus a resource block offers for data transmission  $12 \cdot 7 = 84$  resource elements per slot minus those reserved for pilot symbols and signaling. Resource allocations to a mobile station are valid for at least one TTI. LTE Rel. 8 applies adaptive modulation and coding for PDSCH with modulation schemes QPSK, 16QAM, and 64QAM and Turbo coding with mother code rate 1/3. Given the downlink transport channel processing a large variety of transport block sizes are supported [6]. Additionally, LTE Rel. 8 supports hybrid automatic repeat request (HARQ)

functionality allowing for Chase combining and incremental redundancy. Further details of the LTE physical layer functionalities can be found in [4], [5], [6].

### III. MACRO DIVERSITY SYSTEM MODEL

#### A. Over the Air (OTA) Combining in Downlink Direction

Figure 1 shows the concept of macro diversity as it is used throughout this paper. The same baseband signal  $s(t)$  is transmitted from  $M$  cells ( $M = 2$  in Figure 1) to a mobile station being in macro diversity mode (MD-UE). One of the cells acts as master that controls the scheduling and modulation and coding scheme selection. The other cells are slaves that follow the scheduling decisions of the master cell. The  $M$  copies of the signal  $s(t)$  are generally transmitted with a relative time offset  $\Delta\tau_i$  and experience different channel impulse responses  $g_i(\tau, t)$ ,  $i = 1, \dots, M$ . Assuming transmission starts at time

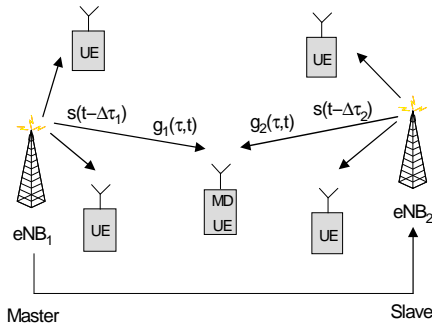

Fig. 1. Macro Diversity Concept

instant  $t = 0$ , the transmitted OFDM baseband signal  $s(t)$  is a weighted sum of orthogonal base functions

$$s(t) = \sum_{k=0}^{N_c-1} x_k \phi_k(t) \quad (1)$$

where  $N_c$  is the number of OFDM subcarriers and  $x_k$  are complex numbers from the set of modulation points [7]. The orthogonal base functions are given by

$$\phi_k(t) = \begin{cases} \frac{1}{\sqrt{T-T_{cp}}} \exp\left(j2\pi \frac{W}{N_c} k(t - T_{cp})\right) & \text{if } t \in [0, T] \\ 0 & \text{otherwise} \end{cases} \quad (2)$$

where  $T_{cp}$  is the cyclic prefix length,  $T$  is the OFDM symbol length and  $W$  is the bandwidth of the signal [7]. No cell specific precoding is applied to the modulation symbols  $x_k$ .

We always assume that the multipath spread  $T_m$ , i.e. the maximal delay of the time-variant channel impulse response  $g(\tau, t)$ , is shorter than the cyclic prefix  $T_{cp}$ . First let the signal  $s(t)$  be transmitted from one cell only. Then the waveform  $r(t)$  at the receiver is

$$r(t) = \int_0^{T_{cp}} g(\tau, t) \cdot s(t - \tau) d\tau + n(t) \quad (3)$$

where  $n(t)$  denotes additive white Gaussian noise. If the same signal  $s(t)$  is transmitted from  $M$  cells with a relative time offset due to asynchronous network operation of  $\Delta\tau_i \geq 0$

where  $\min_i \Delta\tau_i = 0$ ,  $i = 1, \dots, M$  the received signal  $r_{OTA}(t)$  becomes:

$$\begin{aligned} r_{OTA}(t) &= \sum_{i=1}^M \int_0^{T_{cp}} g_i(\tau, t) \cdot s(t - \tau - \Delta\tau_i) d\tau + n(t) \\ &= \int_0^{T_{cp}} \underbrace{\sum_{i=1}^M g_i(\tau - \Delta\tau_i, t)}_{g_{OTA}(\tau, t)} \cdot s(t - \tau) d\tau + n(t) \end{aligned} \quad (4)$$

as long as  $\max_i (T_{m,i} + \Delta\tau_i) \leq T_{cp}$  can be assumed. It is seen that  $r_{OTA}(t)$  has the same form as the signal  $r(t)$ . The impulse response in this case is the over the air combination of the impulse responses of the single links, i.e.  $g_{OTA}(\tau, t) = \sum_i g_i(\tau - \Delta\tau_i, t)$ . From the mobile station point of view the combined impulse response does not impact the data detection algorithm as long as  $T_{m,i} + \Delta\tau_i$  is shorter than the cyclic prefix  $T_{cp}$  for all indices  $i$ ,  $i = 1, \dots, M$ . Otherwise the system suffers from intersymbol interference. Further implications of this assumption are discussed in the next subsection. It should be noted that channel estimation becomes more complex since the combined channel from all  $M$  involved cells needs to be estimated.

#### B. Physical Layer and MAC Layer Synchronization

The concept of downlink macro diversity assumes over the air combining of the signals being transmitted from different cells. In order to avoid interference between adjacent OFDM symbols, the maximal delay of the combined impulse response including the relative time offset due to asynchronous network operation should be smaller than the cyclic prefix. If the maximal relative time offset  $\max_i \Delta\tau_i$  is too large, network synchronization may be required. The required length of the cyclic prefix depends on the distance of the macro diversity cells to the mobile station. Physical layer synchronization requirements for coherent base station cooperation are e.g. discussed in [8]. Since macro diversity relies on incoherent over the air combining, the synchronization requirements may not be as stringent as for coherent combining as long as it can be ensured that the cyclic prefix length is not exceeded.

Figure 2 shows the overall LTE architecture. The eNBs

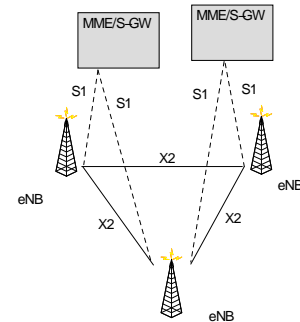

Fig. 2. LTE Overall Architecture

are interconnected by the logical X2 interface. The eNBs are

also connected by the S1 interface to the MME (Mobility Management Entity) and to the S-GW (Serving Gateway). The S1 interface supports a many-to-many relation between MMEs / S-GWs and eNBs [9]. Figure 3 shows the structure of the user plane layer 2 protocols within the eNB. According to [9] the user plane protocol stack includes the protocols PDCP (packet data convergence protocol), RLC (radio link control) and MAC (medium access control). PDCP SDUs (service data unit) are received in the eNB from the S-GW and their header is potentially compressed in the PDCP protocol. The

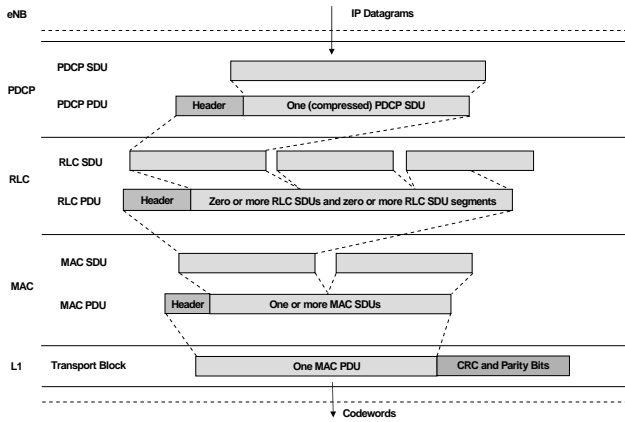

Fig. 3. eNB Protocol Structure

MAC layer scheduler decides the transport block size of the MAC PDU (packet data unit) to be transmitted over the air interface. Based on this decision the RLC protocol provides on request of the MAC layer a RLC PDU of appropriate size to the MAC protocol either by byte-aligned concatenation or segmentation of PDCP PDUs [10]. In macro diversity the same information is transmitted from several cells to the mobile station. According to Figure 3 the same MAC PDU needs to be transmitted from all involved cells which requires a synchronization of the MAC layers across cells. Synchronization means that the content of the MAC PDU, i.e. concatenated/segmented RLC SDUs plus RLC header, as well as the MAC header is identical in all cells.

If macro diversity shall be applied across sites MAC synchronization needs to be achieved over the S1 and X2 interfaces. How this can be efficiently ensured is outside the scope of this paper. MAC synchronization is not only required for macro diversity but also for all network coordination concepts that transmit the same data from different cells. A similar kind of synchronization is required in the LTE Rel. 8 multicast service MBSFN (Multimedia Broadcast Single Frequency Network). Alternatively, remote radio heads (RRH) can be used. RRHs allow the physical separation of the RF from the baseband modules of a site. The baseband modem remains within the cabinet of the base station, whereas the RF chain is located remotely adjacent to the antenna subsystem. All RRH form separate logical cells which are connected via a single S1 interface to the S-GW. Since several RRHs are controlled by one baseband modem, MAC synchronization

requires exchange of information via the backplane of the modem but does not involve the X2 interface. A further advantage is that the latency for backplane coordination is expected to be much smaller compared to the delay over the X2 interface. Therefore delay sensitive information is less impacted in a RRH based macro diversity approach.

Both physical layer as well as MAC layer synchronization are not supported in LTE Rel. 8 and under further discussion for LTE-Advanced [3]. However, for the following simulations we assume perfect synchronization of both kinds for each transmitted MAC PDU in case of macro diversity.

#### IV. SIMULATION ASSUMPTIONS AND RESULTS

According to [13] the RMS delay spread  $\sigma_{RMS}$  of the channel is a measure for the coherence bandwidth  $W_c$ , which in turn is related to the frequency-selectivity of the channel. The larger the RMS delay spread the lower the coherence bandwidth and the higher the frequency-selectivity of the channel. In Table I the RMS delay spread of a single leg and

TABLE I  
RMS DELAY SPREAD

Environment	Single Leg	Two OTA combined Legs
Urban Macro	0.654 $\mu$ s	0.686 $\mu$ s
Suburban Macro	0.173 $\mu$ s	0.184 $\mu$ s
Urban Micro	0.249 $\mu$ s	0.264 $\mu$ s

two OTA combined legs are given for different environments defined in [11]. It is seen that over the air combining increases the RMS delay spread of the channel. Thus the coherence bandwidth is reduced and more frequency-selectivity is added by the second leg. The frequency-selectivity is highest for the urban macro scenario and lowest in the suburban macro scenario for both one and two legs.

For the simulations at link level we consider one mobile station that is connected either to one or to two cells. The mobile station is located in the middle of the cells facing the boresights of both antennas, i.e. the antenna gains are the same for both cells. The geometry at the mobile station is varied by adjusting the Tx power accordingly. The receiver in the mobile station including the decoding of the Turbo code for fading channels is not fully simulated at link level but its performance is approximated by the mutual information effective SINR metric (MIESM) as proposed in [12] based on AWGN link level results. The AWGN link level results are calibrated within WG1 of the EASY-C project ([www.easy-c.de](http://www.easy-c.de)). As long as the multipath spread is shorter than the cyclic prefix the channel stays approximately flat over a subcarrier. Therefore the increased frequency-selectivity of the channel can only be exploited with a forward error correcting channel code that encodes across several PRBs as it is the case in LTE Rel. 8 [5].

Figure 4 shows the block error rate (BLER) of the first HARQ transmission with one and two legs for the channel models of [11] and a LTE Rel. 8 Physical Downlink Shared Channel (PDSCH). The same modulation and coding scheme

(MCS) was transmitted in each TTI. Additional link assumptions are given in Table II. The same SNR loss model for one and two legs has been applied. This assumption may not be justified and needs further investigation. It is seen that for

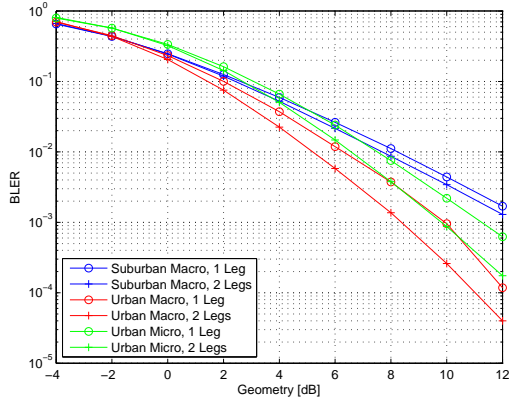

Fig. 4. BLER for one and two Radio Legs

the suburban macro scenario the gains are relatively small, whereas for urban macro and urban micro models the SNR improvement due to frequency-selectivity at a BLER of  $1e-3$  is between 1 - 2 dB. Since the transmit power is normalized with the number of legs, these gains are solely due to increased frequency-selectivity of the channel. The results are in a good agreement with the RMS delay spread characteristics shown in Table I. It is seen in Figure 4 that the BLER performance for a channel is the better the larger its RMS delay spread is. Moreover, since the RMS delay spread is increased by adding the macro diversity leg, the BLER performance is further improved.

The potential benefit of macro diversity was also investigated in a simplified system level setup, see Figure 1. Similar to the link level scenario, two cells separated by a distance of  $d = 1000\text{m}$  serve on average  $N = 7$  UEs each that are connected with one leg (legacy UE) to their serving cell and one UE that is operated either in regular or in macro diversity mode (MD-UE) and controlled by a master cell. All channel realizations are drawn from the same distribution

TABLE II  
LINK LEVEL ASSUMPTIONS

SNR Loss Model	$\max(1 \text{ dB}, -0.35 \cdot \text{SNR [dB]} + 1.6 \text{ dB})$
Tx Antennas	One per Cell
Rx Antennas	One at UE
PDCCH Signaling	3 OFDM symbols/TTI
Cell Power	Identical for both Cells Normalized with the Number of Legs
Power Allocation	Uniform over allocated PRBs
Radio Channel	Suburban Macro, Urban Macro Urban Micro [11]
Tx Bandwidth	5 MHz (25 PRBs)
Allocated PRBs/TTI	(0, 4, 8, 12, 16, 20)
MCS	QPSK, $R = 1/2$

TABLE III  
SYSTEM LEVEL ASSUMPTIONS

MAC Scheduler	Proportional Fair in Time and Frequency PRB and MCS Allocation per TTI
HARQ Operation	No HARQ Retransmissions
Cell Power	Identical for both Cells
CQI Reporting (MD-UE)	One CQI/PRB/TTI of OTA combined Channel to Master Cell
CQI Reporting (Legacy UE)	One CQI/PRB/TTI to Serving Cell
Radio Channel	Suburban Macro [11]
Master/Slave Cell Synchronization	Ideal Physical Layer and MAC Layer Synchronization
X2 Signaling (Master $\rightarrow$ Slave)	MCS and PRB Allocation sent from Master Cell without Delay

[11] and only results yielding geometries between -3 dB and 17 dB are taken into account because such geometries are typically observed in a macro scenario. The MD-UE estimates the over the air combined channel and reports the channel quality information (CQI) of the combined channel to the master cell. The MAC scheduler that controls the allocation of PRBs to the MD-UE is located in the master cell. This PRB allocation is communicated to the slave cell over a fast backhaul link (X2 interface). The slave cell serves the MD-UE on the PRBs allocated by the master cell and distributes the remaining PRBs to the legacy users connected to it. The MD-UE has therefore always highest priority in the slave cell. We assume that this communication takes place with negligible delay. The assumptions for the system level simulations are given in Table III. Remaining assumptions are as in Table II.

The impact on cell throughput of using the macro diversity mode in the MD-UE is presented in Figure 5. The cumulative density function (cdf) of the cell throughput is shown for both the case that macro diversity is used for the MD-UE and the case that it is not. The contribution of the MD-UE to the cell

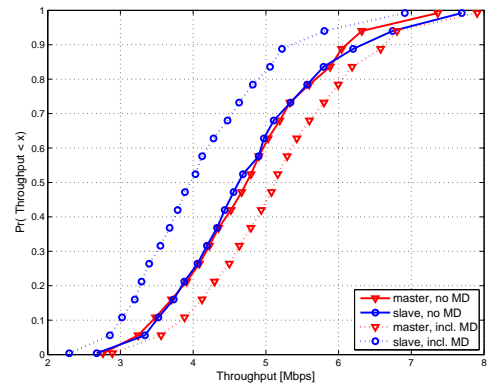

Fig. 5. Cell Throughput of Master and Slave Cells

throughput must only be added to one cell when operated in macro diversity mode since in this case the transmitted MAC PDUs are identical in both cells. In Figure 5 it is included in the master cell throughput. Apparently, the master cell

throughput is significantly increased when operating one UE in macro diversity mode. On the other hand, the resource blocks allocated to the MD-UE are no longer available in the slave cell which therefore experiences a penalty in cell throughput. It is seen that this loss is larger than the gain for the master cell. Scheduling algorithms should therefore be designed to reduce this effect.

It is also instructive to consider the user throughput gain of the MD-UE when comparing macro diversity with the regular mode. We categorize the applicability of macro diversity in terms of channel conditions at the MD-UE. The geometry  $\Gamma$  in our case with one serving cell and one interfering cell can be expressed as  $\Gamma = \frac{P_S}{P_I + P_N}$  where  $P_S$  and  $P_I$  are the average powers (including path loss and shadow fading) received by the UE from the serving and interfering cell, respectively and  $P_N$  is the thermal noise power at the UE. When operating in macro diversity mode,  $P_I$  is transformed into useful signal power, i.e. the geometry becomes  $\Gamma_{MD} = \frac{P_S + P_I}{P_N} > \Gamma$  due to interference reduction. If  $\Gamma$  is large implying  $P_S \gg P_I$  the geometry increase is reduced when compared to the case that  $P_S$  and  $P_I$  have similar magnitude. The results of this effect are presented in Figure 6 where the channel conditions are

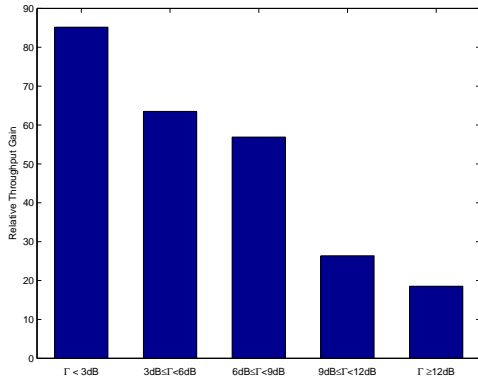

Fig. 6. Relative User Throughput Gain due to Macro Diversity

classified into a range of unfavorable ( $\Gamma < 3$  dB) to highly favorable ( $\Gamma > 12$  dB) geometries. The average throughput gains experienced by the MD-UE when using macro diversity are shown as a function of the single leg geometry  $\Gamma$ . As expected, the gains are larger at lower geometries  $\Gamma$ . It can be concluded from Figure 6 that the penalty of macro diversity for the slave cell is much easier justified in the cases where macro diversity actually provides a significant user throughput gain. It is therefore necessary to make a careful assessment under which conditions the usage of macro diversity should be considered.

We note here that we have used a simplified scenario that serves mainly to illustrate some potential questions that need to be raised before using macro diversity on a large-scale network. In particular, the gain due to interference reduction is expected to be smaller if more interferers are present.

## V. CONCLUSION

In this paper the concept of macro diversity was investigated for LTE-Advanced. It was shown that over the air combining offers a frequency-selectivity gain due to an increased RMS delay spread of the combined channel. Further gains are an increase in the received power and a reduction of the inter cell interference. The performance improvement is largest at cell edge and diminishes if the mobile stations moves towards cell center. Those gains for the mobile station operated in macro diversity mode come at the expense of a throughput loss for legacy mobiles in the slave cell since less PRBs are available for them. Due to this trade-off between MD-UEs and legacy UEs radio resource management algorithms controlling the operating mode and efficient scheduling strategies are required. Additionally, several open issues of macro diversity and network coordination in general were identified that require further investigation in order to predict the capacity enhancements more reliably. This includes channel estimation of multiple radio legs, synchronization of the physical and the MAC layer as well as fast communication between master and slave cells. MAC layer synchronization and fast master/slave communication impact the X2 interface if master and slave cells belong to different sites. Therefore RRHs provide a promising alternative since the coordination between master and slave involves only the backplane of the baseband modem.

## ACKNOWLEDGEMENT

The authors acknowledge the cooperation with all project partners within the EASY-C project and the support by the German Federal Ministry of Science and Education (BMBF).

## REFERENCES

- [1] 3GPP TR 25.814, *Physical Layer Aspects for Evolved UTRA (Release 7)*, v7.1.0, Sept. 2006
- [2] M. Karakayali, G. Foschini, R. Valenzuela, *Network Coordination for spectrally efficient Communications in Cellular Systems*, IEEE Wireless Communications Magazine, August 2006
- [3] 3GPP TR 36.913, *Requirements for further Advancements for E-UTRA (LTE-Advanced) (Release 8)*, v8.0.0, June 2008
- [4] 3GPP TS 36.211, *E-UTRAN Physical Channels and Modulation (Release 8)*, v8.4.0, Sept. 2008
- [5] 3GPP TS 36.212, *E-UTRAN Multiplexing and Channel Coding*, v8.4.0, Sept. 2008
- [6] 3GPP TS 36.213, *Physical Layer Procedures*, v8.4.0, Sept. 2008
- [7] M. Sandell, *Design and Analysis of Estimators for Multicarrier Modulation and Ultrasonic Imaging*, PhD Thesis, Luleå University of Technology, Sweden, 1996
- [8] V. Jungnickel, T. Wirth, M. Schellmann, T. Haustein, W. Zirwas, *Synchronization of Cooperative Base Stations*, IEEE International Symposium on Wireless Communication Systems, 2008
- [9] 3GPP TS 36.300, *E-UTRAN Overall Description (Release 8)*, v8.6.0, Sept. 2008
- [10] 3GPP TS 36.422, *E-UTRAN Radio Link Control (RLC) Protocol Specification (Release 8)*, v8.3.0, Sept. 2008
- [11] 3GPP TR 25.996, *Spatial Channel Model for Multiple Input Multiple Output (MIMO) Simulations (Release 7)*, v7.0.0, June 2006
- [12] K. Brueninghaus, D. Astely, T. Sälzer, S. Visuri, A. Alexiou, S. Karger, G.-A. Seraji, *Link Performance Models for System Level Simulations of Broadband Radio Access Systems*, IEEE International Symposium on Personal, Indoor and Mobile Radio Communications, 2005
- [13] M. P. Fitton, A. R. Nix, M. A. Beach, *A Comparison of RMS Delay Spread and Coherence Bandwidth for Characterisation of Wideband Channels*, IEE Colloquium on Propagation Aspects of Future Mobile Systems, 1996